

AMT 885/835/825/PVS15

P/N : 300824-101

SUBREV : K

DRAWN BY : C THOMSON

DATE : 27 SEP 2011

SHEET 1 OF 9

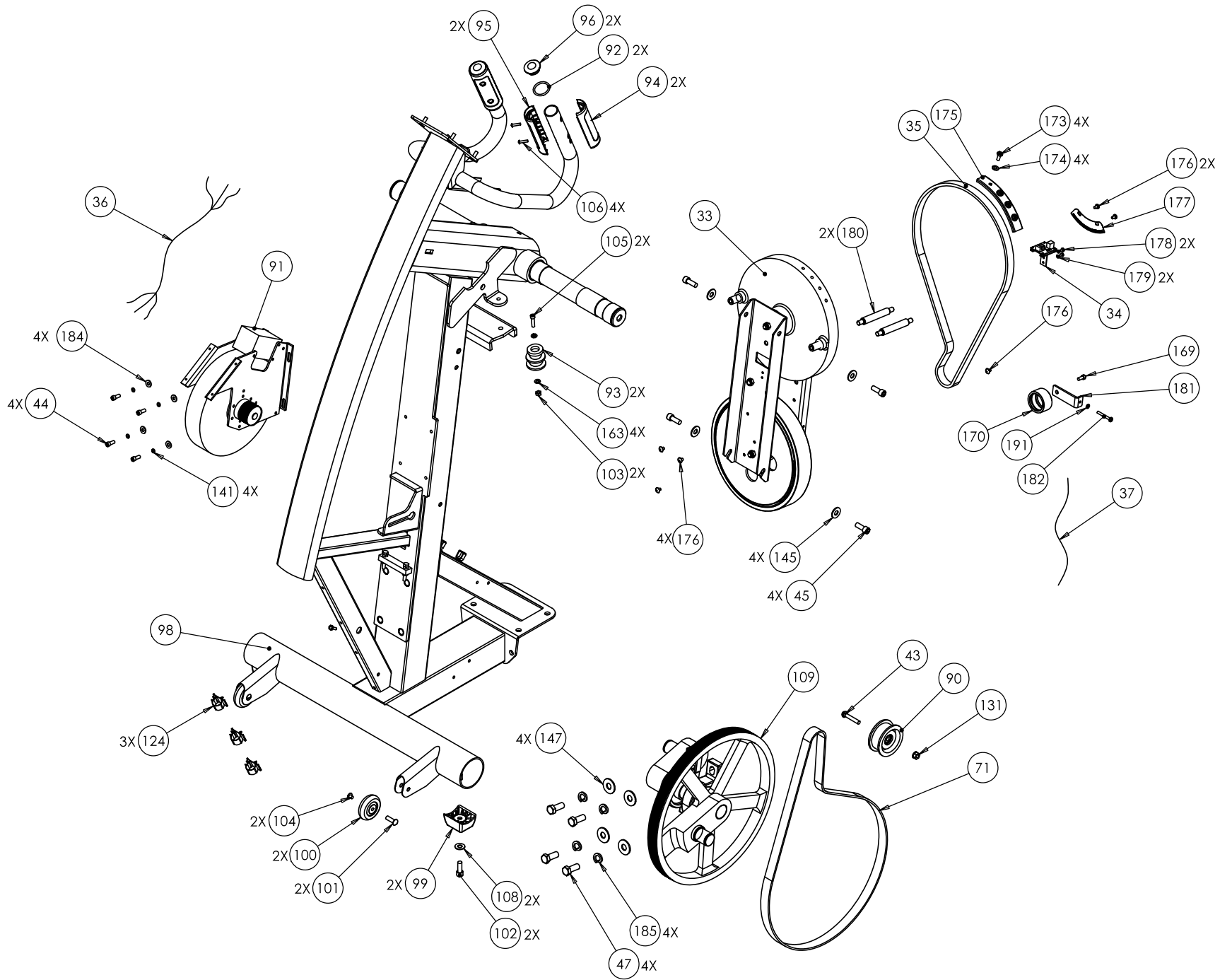

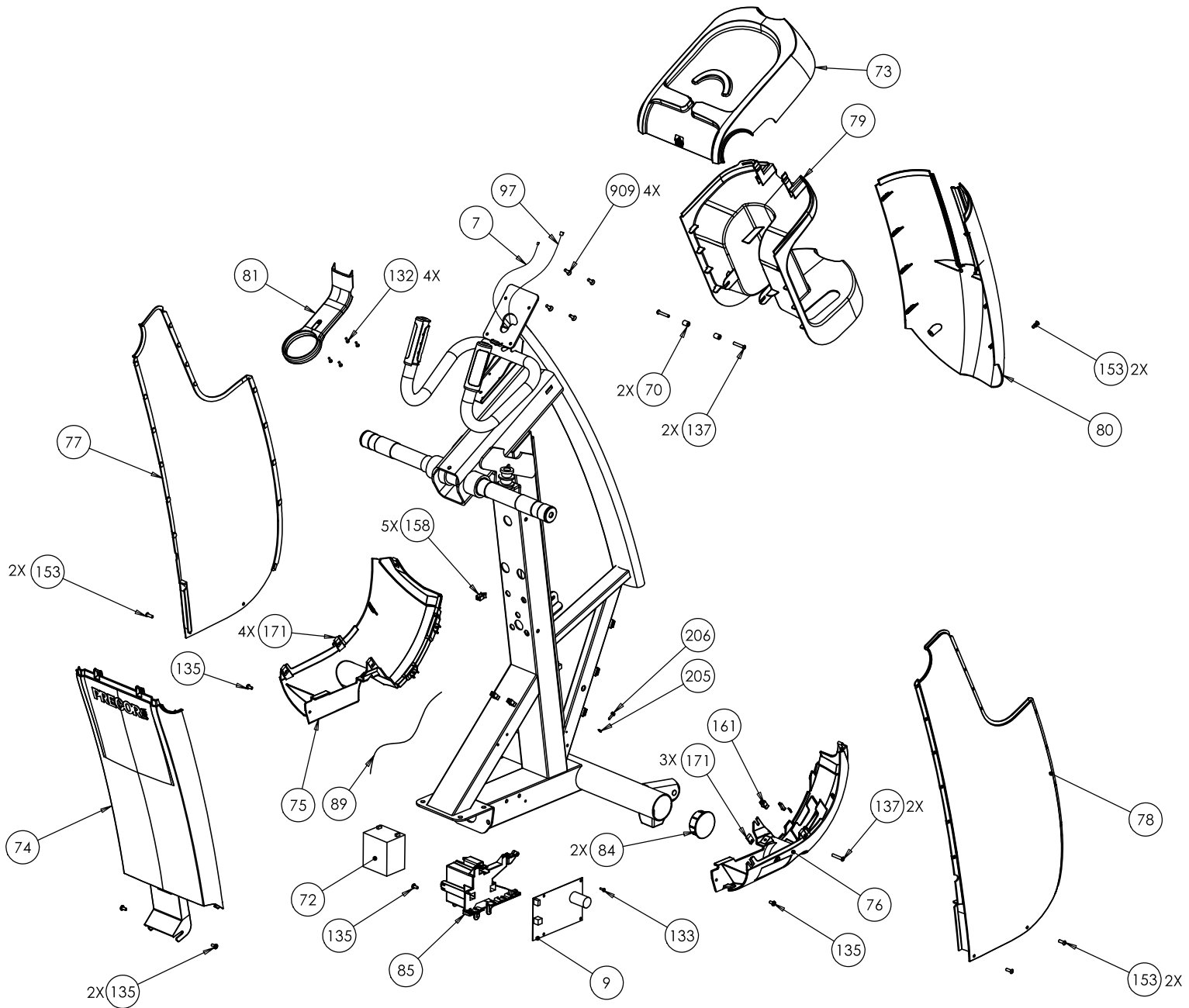

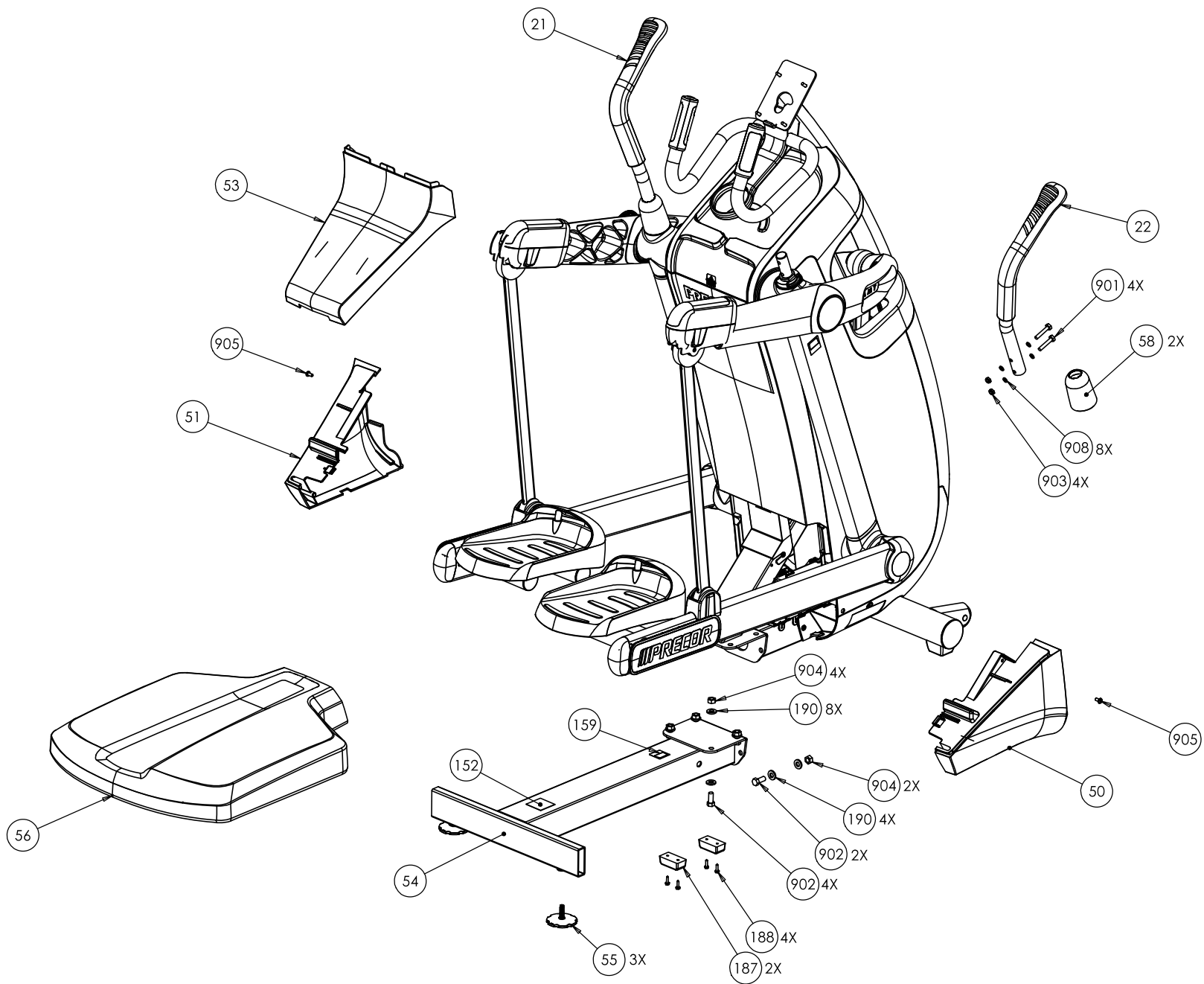

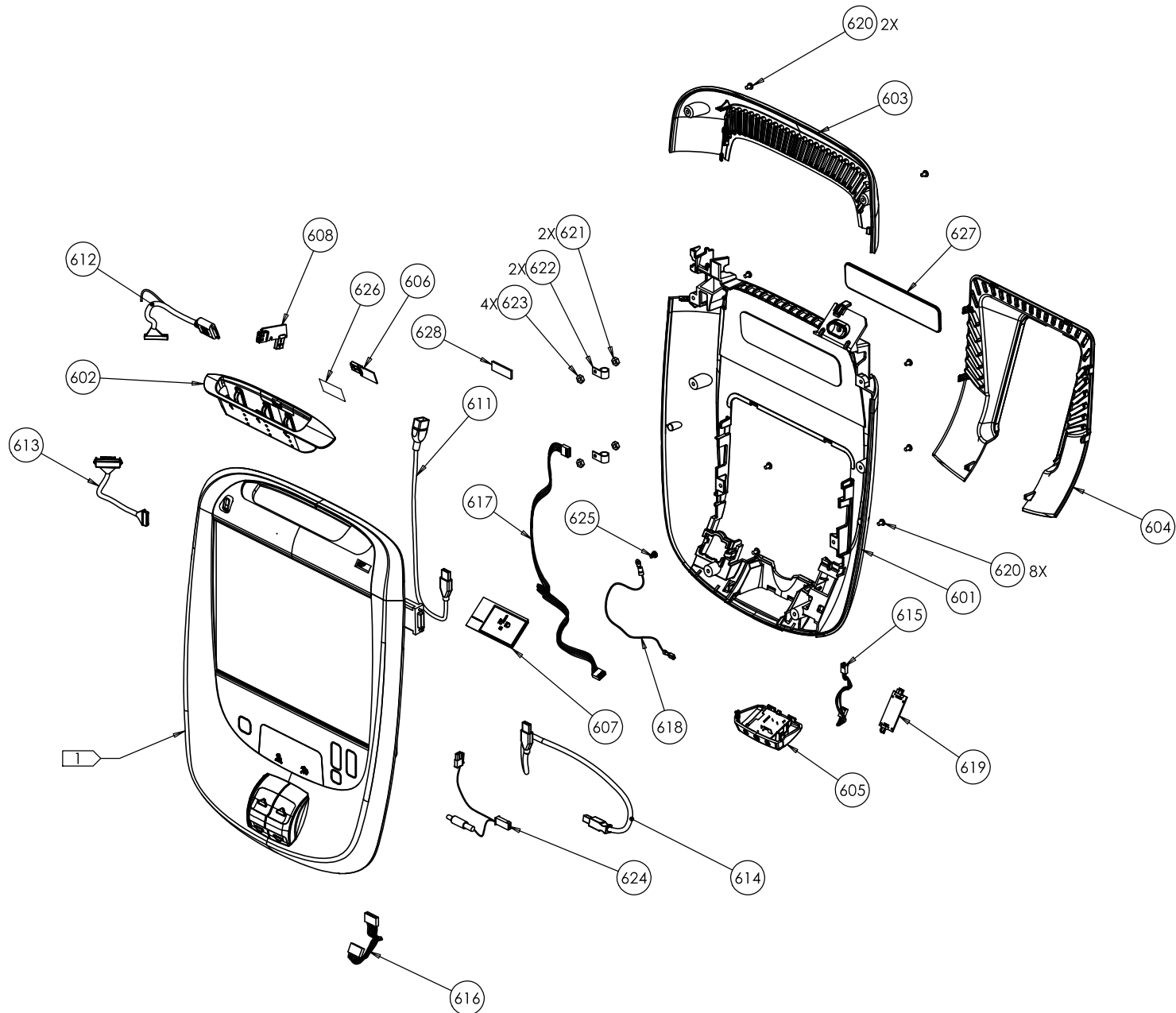

NOTES:

- 1 THIS IS A COMPLETE DISPLAY ASSEMBLY, PACKAGED FOR SHIPPING.
- ORDER BUBBLE #650 FOR WARRANTY REPLACEMENTS, OR ANY RELATED PART NOT SHOWN SEPARATELY.
- ORDER BUBBLE #600 FOR PURCHASED REPLACEMENTS, OR ANY RELATED PART NOT SHOWN SEPARATELY.

AMT 885 ONLY

PAGE	OF	DWG. NO.	SUBREV
6	9	300824-101	K

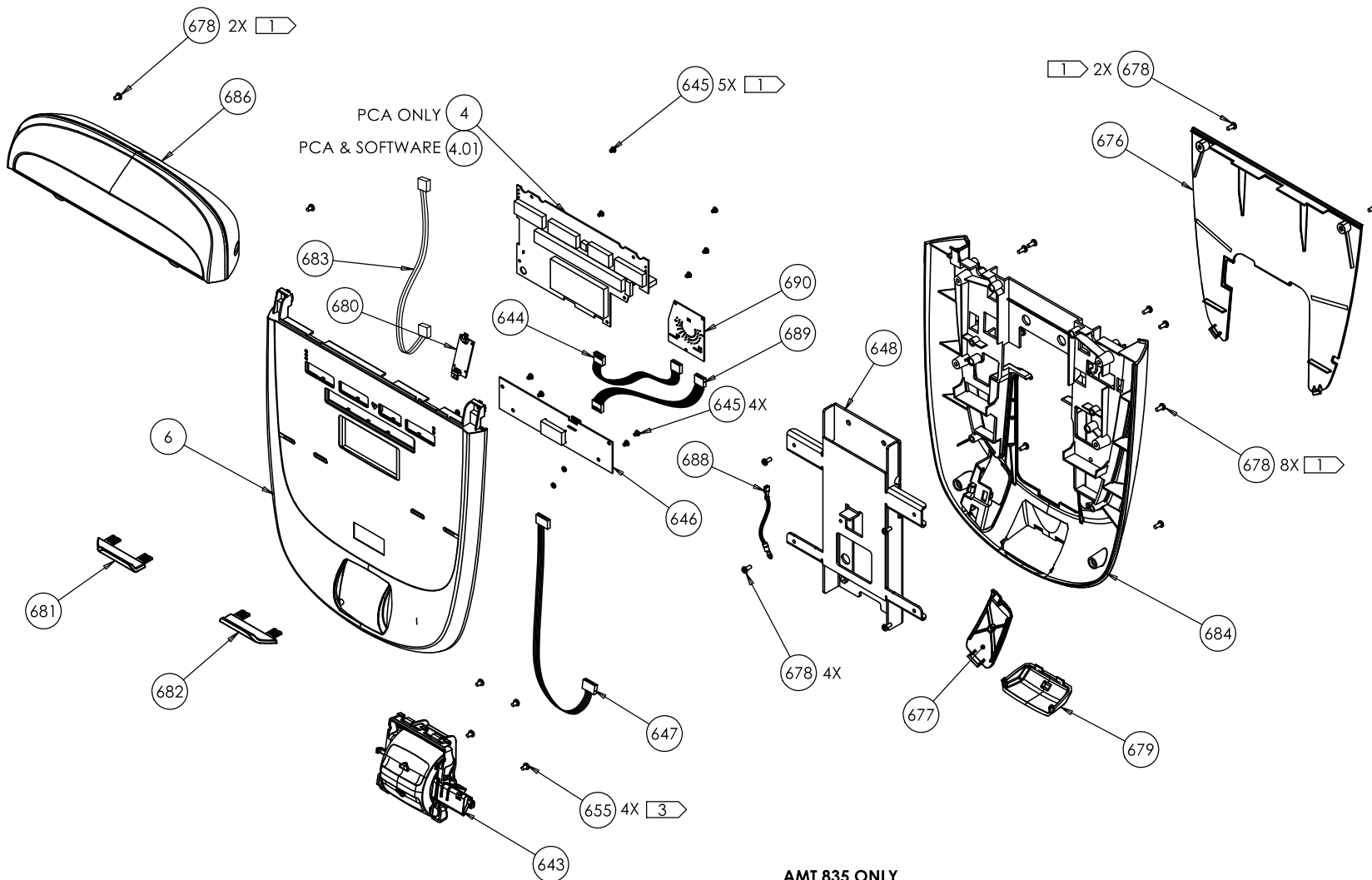

AMT 835 ONLY

NOTES:

- [1] TORQUE TO 10 IN-LB ± 1 IN-LB.
- [2] TORQUE TO 19 IN-LB ± 1 IN-LB.
- [3] TORQUE TO 6 IN-LB, MAX.

PAGE	OF	DWG. NO.	SUBREV
7	9	300824-101	K

4

3

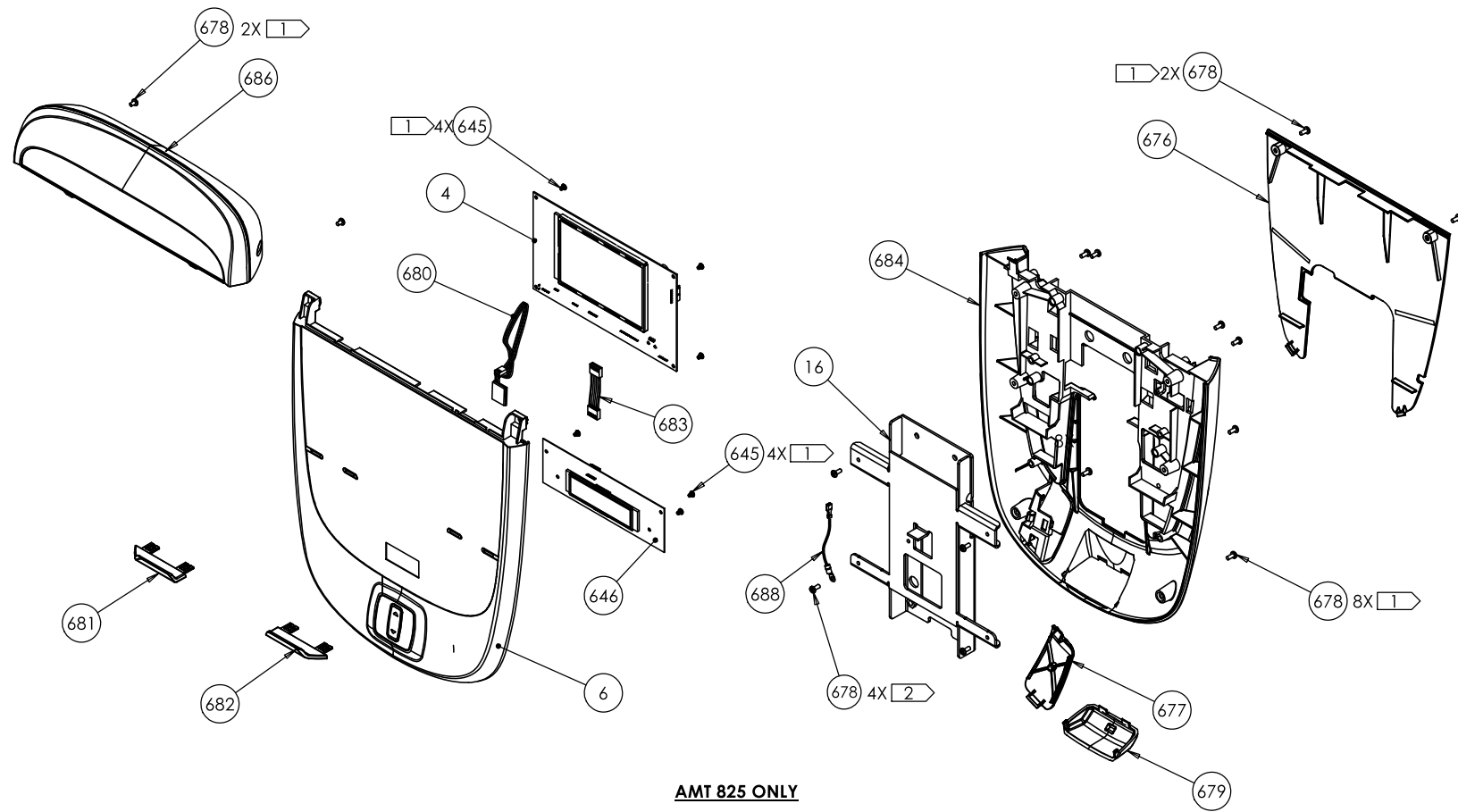

2

1



AMT 825 ONLY

NOTES:

-  TORQUE TO 10 IN-LB ± 1 IN-LB.
-  TORQUE TO 19 IN-LB ± 1 IN-LB.

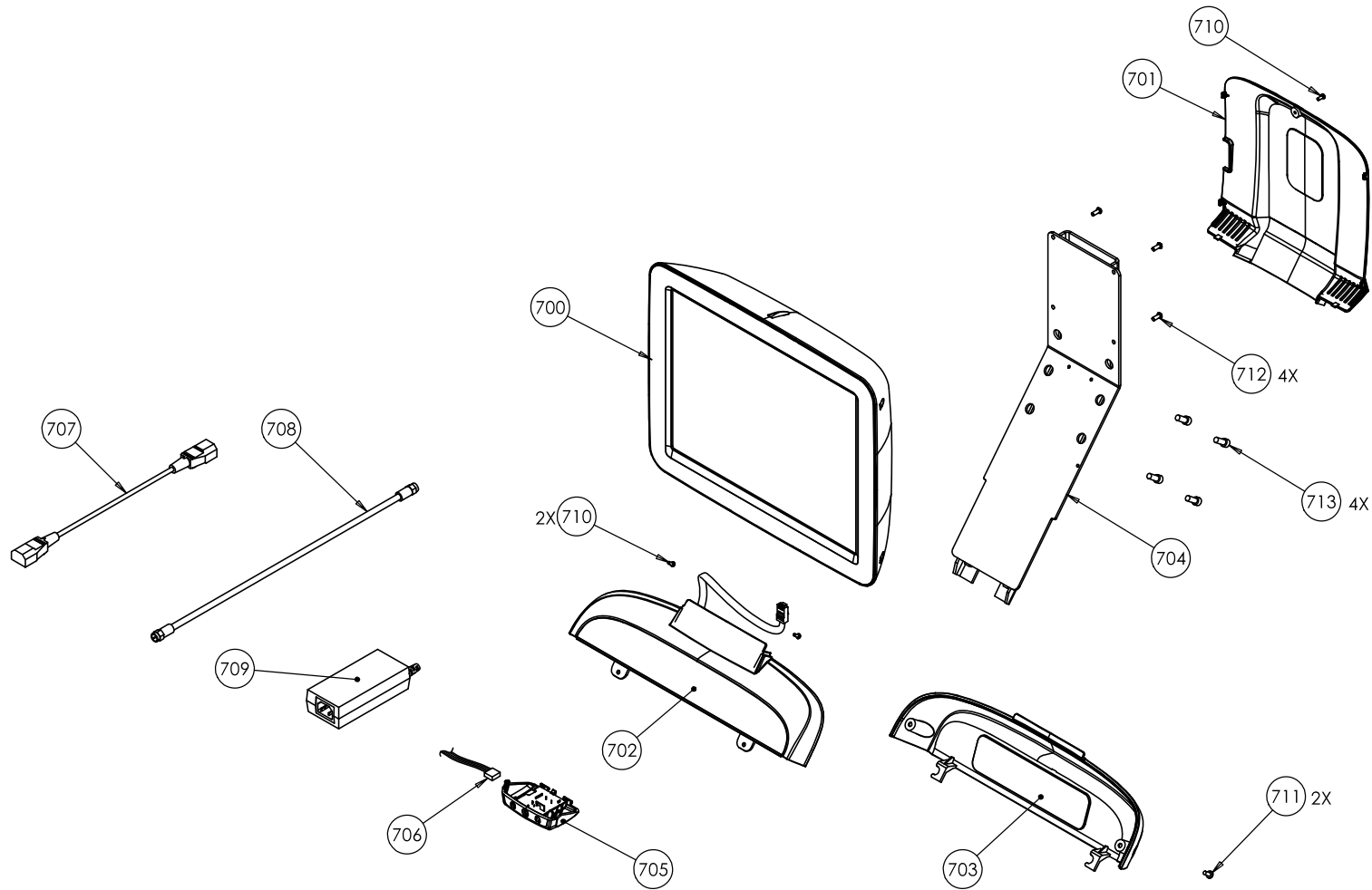

PVS15

AMT10-885 (serial code AADR + ATTE)

Part Number	Description	Bubble Number
PPP00000044905096	ASSY,CBL,MOD,8P8C,1-1,SILVER,96"	7
PPP00000049702102	ASSY,LOWER PCA & SW,GEN-BRAKE	9
PPP00000049183101	ASSY, MOVING HANDLEBAR, LH	21
PPP00000049183102	ASSY, MOVING HANDLEBAR, RH	22
PPP00000049196103	ASSEMBLY,CONNECTING ROD,UPPER	29
PPP00000049185111	ASSY,FRONT ARM,LH	30
PPP00000049185112	ASSY,FRONT ARM ,RH	31
PPP00000049399101	ASSEMBLY,EDDY BRAKE	33
PPP000000300460101	PCA, HORIZONTAL POSITION SENSOR ASS	34
PPP00000049116101	STD BELT, HORIZ. BRAKE	35
PPP00000049403036	ASSY, CABLE, V-BRAKE EXTENSION,36"	36
PPP00000049441036	ASSY,CBL,MOD,4P4C,1-1,SILVER,36"	37
PPP00000049219103	LINK PIN, LONG	38
PPP00000AAHN063003	RING, RETAINER, 5/8, EXTERNAL	40
PPP00000AAHN110005	RING,RETAINER,EXTERNAL,TREADS	41
PPP00000ABKN045006	RETAINER, EXTERNAL, 45MM	42
PPP00000BACN031175	BOLT, CARRIAGE, 5/16-18 X 1.75	43
PPP00000CAMN025075	SCREW, SKHD, 1/4 X 0.75, ZN,(MECH P	44
PPP00000CAMN038100	SCREW, SKHD, 3/8-16 X 1, ZN, (MECH	45
PPP00000HCCN031350	SCREW,HEX,GR5,5/16-18X3-1/2, ZN	46
PPP00000HCCN050150	SCREW,HEX,GR5,1/2-13 X 1.50, MECHAN	47
PPP00000KACN050019	LOCKNUT,HALF,1/2-13,ZN	49
PPP00000039904101	COVER, FRAME JOINT, RIGHT	50
PPP00000039904102	COVER, FRAME JOINT, LEFT	51
PPP00000039944102	ASSEMBLY, FRAME JOINT, TOP,ATLAS	53
PPP00000049108102	ASSEMBLY,FRAME,BASE	54
PPP00000039916103	FOOT, ADJUSTING,NO LOGO	55
PPP00000049710101	ASSY, FOOT PLATFORM, BOXED	56
PPP00000039903101	COVER, HANDLEBAR	58
PPP00000010196124	SPACER, NYLON, .5 OD, .257 ID, .625	70
PPP00000010217143	BELT, DRIVE, 610J10 POLY V,61"	71
PPP000000012258040	BATTERY,SLA,12V,4AH,.187 TABS	72
PPP000000039900103	COVER, TOP	73
PPP000000039901102	COVER, BACK, NEW LOGO	74
PPP000000039941101	ASSY, COVER, LOWER LEFT	75
PPP000000039942102	20ASSY, COVER, LOWER RIGHT	76
PPP000000039905103	SIDE COVER, LEFT	77
PPP000000039905104	SIDE COVER, RIGHT	78
PPP000000049804103	ASSY, COVER, LINKAGE	79
PPP000000039907102	COVER, FRONT	80
PPP000000300405101	SUPPORT, WATER BOTTLE	81
PPP000000039914101	CAP, UPPER ARM CASTING	83
PPP000000039919101	CAP, FRAME, ROUND TUBE	84
PPP000000039923101	BRACKET, BATTERY/PCA	85
PPP000000039924101	ARM COVER, TOP W/ OVERMOLD	86
PPP000000039925102	ARM COVER, BOTTOM	87
PPP000000039930101	WASHER, THRUST, PLASTIC	88
PPP000000045250017	ASSY,CBL,2C,18AWG,QK DISC,17"	89
PPP000000046825101	PULLEY,IDLER,FLANGED	90

AMT10-885 (serial code AADR + ATTE)

Part Number	Description	Bubble Number
PPP00000048370103	ASSEMBLY,SP,GENERATOR,AMT,CLIMBER	91
PPP00000010115113	O-RING, ROUND, 1.25ID X .139	92
PPP00000039932101	END STOP CUSHION	93
PPP00000042713102	HHRH SENSOR, TOP	94
PPP00000042714102	HHRH SENSOR, BOTTOM	95
PPP00000042730101	PLUG, HHRH, HANDLE BAR END	96
PPP00000047342045	ASSY, CABLE, HHRH PCA TO GRIP, W/SH	97
PPP00000049195101	FRONT FOOT	99
PPP00000049911101	WHEEL, TRANSPORT, SOLID, ORANGE	100
PPP0000KBKCN025100	NUT, BARREL, STEEL, TRUSS HEAD, UNC, 1/4	101
PPP00000CAMN038100	SCREW, SKHD, 3/8-16 X 1, ZN, (MECH	102
PPP00000012112101	RIVNUT, INSERT, HEX, 1/4-20	103
PPP00000MCCN025031	SCREW, 1/4-20 X 5/16, MACH, TRUSS PH	104
PPP00000CAMN025100	SCREW, SKHD, 1/4-20X1, ZN (MECH PLATIN	105
PPP00000TCNN016075	SCREW, BTHD, 8-32X.75, SS	106
PPP00000KGCN025020	LOCKNUT, STARWASHER, 1/4-20, ZN	107
PPP00000WRCN038011	WASHER, GRADE 8, 3/8, 13/32 ID, 13/16OD	108
PPP00000049150102	ASSEMBLY, INPUT CRANK	109
PPP00000049155102	ASSEMBLY CONNECTING ROD, LOWER, UNP	110
PPP000000300168101	ASSEMBLY, CAST TIE ROD	111
PPP00000049163104	ASSEMBLY, REAR LINK	112
PPP00000039915101	CAP, FOOT PEDAL TUBE	113
PPP00000039917101	ENDCAP, STAIRARM, FRONT, INNER	114
PPP00000039917102	ENDCAP, STAIRARM, FRONT, OUTER	115
PPP00000039943101	ASSY, ENDCAP	116
PPP00000039920101	STAIR ARM LOGO, BASE	117
PPP00000039920104	STAIR ARM LOGO, PLATE, NEW LOGO	118
PPP00000039931102	ASSEMBLY, FOOT PEDAL	119
PPP00000049167103	WELDMENT, STAIRARM, LH, PNTD	121
PPP00000049167104	WELDMENT, STAIRARM, RH, PNTD	122
PPP00000CAMN025250	SCREW, SKHD, 1/4-20X2.50, MECHANICAL Z	123
PPP00000012349212	CABLE CLIP, PUSH MOUNT, 0.750" BUNDLE	124
PPP00000PPCN019100	SCREW, S/T, #10X1.0, FLATHD, PHIL, CLEAR	125
PPP00000TFTN025075	SCREW, BTHD, 1/4-20X3/4, BLK SHARPERIZ	126
PPP00000WBCN025006	WASHER, FLT, 1/4X.500X.063, ZN (MECH	127
PPP00000049980101	ASSEMBLY, UPPER ARM, LH	129
PPP00000KDCN031025	LOCKNUT, FULL 5/16-18, ZINC	130
PPP00000KGCN031027	LOCKNUT, STARWASHER, 5/16-18, 1/2	131
PPP00000MGCN016050	SCREW, MCH, 8-32X1/2, PANHD, PHIL,	132
PPP00000MGTN016050	MACHINE SCREW, 8-32 X 1/2, PHIL PAN	133
PPP00000MGTN016150	SCREW, MACHINE, 8-32X1.5, PANHD, PH	134
PPP00000PANTN025050	SCREW, S/T, #1/4-20X1/2, PANHD, PHIL, TR	135
PPP00000TFTN025150	SCREW, BUTTON HEAD, 1/4-20 X 1.50,	137
PPP00000WAKNN032004	WASHER, WAVE, SSB-0158	139
PPP00000WAKNN046006	WASHER, WAVE, SSB-0217	140
PPP00000WALCN025006	WASHER, SPLIT LOCK, 1/4 MED,	141
PPP00000049980102	ASSEMBLY, UPPER ARM, RH	142
PPP00000WALCN038009	WASHER, 3/8 SPLIT LOCK, ZINC	143
PPP00000WTCN031008	WASHER, GRADE 8, 5/16, ID=.375, OD=.	145

AMT10-885 (serial code AADR + ATTE)

Part Number	Description	Bubble Number
PPP0000WNCN050005	WASHER, FLAT, CUSTOM, 1/2, ID=.531,	146
PPP0000WRCN050010	WASHER, GRADE 8, 1/2, ID=.531, OD=1.	147
PPP0000WCCN038008	WASHER, FLT, 3/8X1.00X.083	148
PPP0000HCCT038050	SCREW, HEX, GR 5, 3/8-16 X 1/2, ZN,	151
PPP00000039945101	LABEL, CAUTION STEP PLATFORM	152
PPP0000TFTN025075	SCREW, BTHD, 1/4-20X3/4, BLK SHARPERIZ	153
PPP00000039910101	SPACER, PLASTIC, LONG	155
PPP00000039910102	SPACER, PLASTIC, SHORT	156
PPP000000049205101	SPACER, UPPER TIE ROD, NYLON	157
PPP000000011278101	CABLE CLAMP, INSERT	158
PPP000000039939101	LABEL, CAUTION	159
PPP0000HADCN025150	GR5, STEEL, UNC, FULL THREAD, HEX H	161
PPP000000039933102	COVER, LOWER LINK	162
PPP00000WBCN025006	WASHER, FLT, 1/4X..500X.063, ZN (MECH	163
PPP000000049178101	PRECOR LOGO	165
PPP000000011278101	CABLE CLAMP, INSERT	166
PPP000000049205102	SPACER, UPPER CONN ROD, NYLON	167
PPP00000CATE031050	SCREW, SKHD, 5/16-18X0.50, BLK SHARPER	169
PPP000000049117101	ASSEMBLY, IDLER PULLEY	170
PPP000000010136108	CLIP, U TYPE, TINNERMAN, 1/4-20	171
PPP00000HMCN006015	SCREW, HEX HD, M8XP1.0X15MM	173
PPP0000WAJCN007002	WASHER, SPLIT LOCK, METRIC, ID=6.5M	174
PPP000000049053101	BELT CLAMP	175
PPP00000MMCE005008	SCREW, M5 X P.08 X 8MM, PHIL, ZINC	176
PPP000000049051101	ENCODER STRIP	177
PPP00000MMCN004008	SCREW, M4 X 8MM, PHIL, ZINC	178
PPP0000WAJCN004001	WASHER, SPLIT LOCK, STEEL, METRIC,	179
PPP000000049291101	TENSIONER BRACKET	181
PPP0000M14EA001101	SCREW, HEXHD M5 X 40L, W/FLAT WASHE	182
PPP0000M14BA001101	SCREW, BUTHD, PHIL, M5 X 8L	183
PPP00000WBCN025006	WASHER, FLT, 1/4X..500X.063, ZN (MECH	184
PPP0000WALCN050013	WASHER, 1/2 SPLIT LOCK	185
PPP000000031074104	FOOT, FIXED,	187
PPP00000PKCN019075	SCREW, S/T, #10X.75, WSHHXHD, ZN	188
PPP00000WRCN044013	WASHER, GRADE 8, 7/16, ID=.471, OD=.	190
PPP0000WAJCN005001	WASHER, SPLIT LOCK, STEEL, METRIC,	191
PPP000000049173105	WELDMENT, UPPER ARM, PAINTED	193
PPP00000HMCN012030	SCREW, HEX HD, METRIC, GRADE 8.8, F	194
PPP00000WKCNO12002	WASHER, METRIC, PLAIN, NARROW, 12MM X 2	195
PPP0000PANTA019075	SCREW, S/T, #10-24X0.75, PANHD, PHIL, T	197
PPP000000300445102	HARDWARE KIT, AMT10	200
PPP000000057029102	CS REPAIR KIT, UPPER ARM ATTACH	201
PPP000000057046101	AMT, FRONT ARM, REPLACEMENT KIT	203
PPP0000WAMCN019002	WASHER, LOCK, EXT TOOTH, #10	205
PPP00000PKCN019075	SCREW, S/T, #10X.75, WSHHXHD, ZN	206
PPP000000057069102	KIT, DISPLAY, P80, AMT, NA, ATSC/NTSC, W-	600
PPP000000057069602	RMFRD DISPLAY, P80, AMT, NA, ATSC/NTSC,	650
PPP000000012771103	BEARING, CYLINDRICAL ROLLER, RADIAL,	850
PPP00000HCCN031175	SCREW, HEX, GR 5, 5/16-18X1.75, ZN	901

AMT10-885 (serial code AADR + ATTE)

Part Number	Description	Bubble Number
PPP0000HFMT044100	SCREW, GRADE 8, 7/16-20 X1,HEX CAP,	902
PPP00000KGCN031027	LOCKNUT,STARWASHER,5/16-18,1/2	903
PPP0000KBPMN044034	NUT, HEX, 7/16-20, GRADE 8, MECH ZI	904
PPP0000PANTN025050	SCREW,S/T,#1/4-20X1/2,PANHD,PHIL,TR	905
PPP00000WBCN031007	WASHER,FLT,5/16X.688X.065, ZN	908
PPP0000MACCN025062	MACHINE SCREW, 1/4-20, [FLAT HEAD,	909